

OVERALL ASSEMBLY DIMENSIONS:

EXTRENAL - 90 x 55 x 40

INTERNAL - 85 x 50 x 33.5

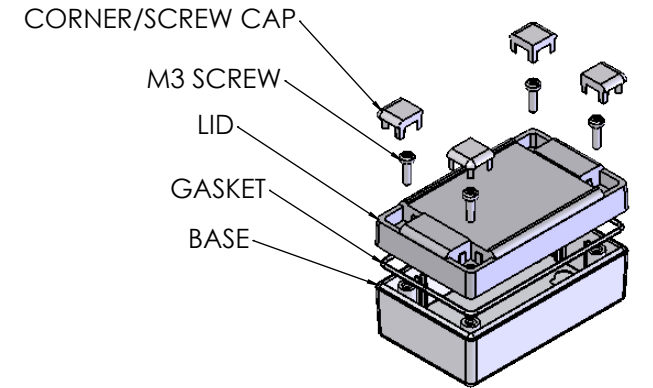

ISO VIEW  
1:3

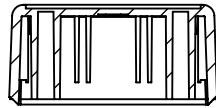

SECTION C-C

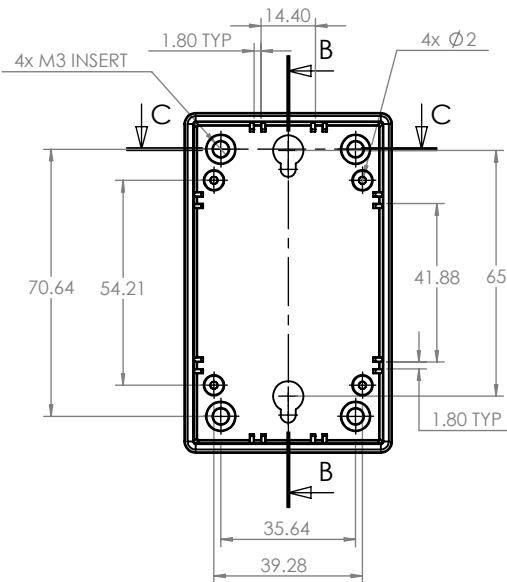
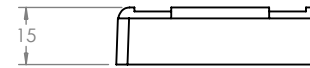

BASE

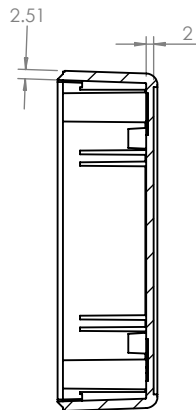

SECTION B-B

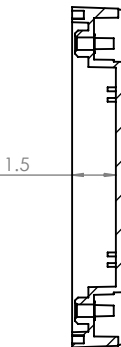
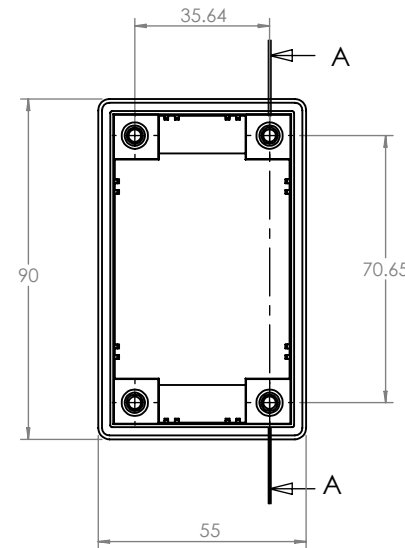

SECTION A-A

LID

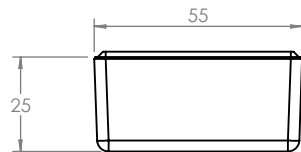

<p><b>CAMDENBOSS®</b> CONNECT. ENCLOSE. INNOVATE.</p> <p>JAMES CARTER RD, MILDENHALL, SUFFOLK. IP28 7DE TEL: 01638 716101 FAX: 01638 716554 EMAIL: Sales@CamdenBoss.com WEB: www.CamdenBoss.com</p>				UNLESS OTHERWISE SPECIFIED: DIMENSIONS ARE IN MILLIMETERS		DO NOT SCALE DRAWING		REVISION. B	
				GENERAL TOLERANCES +/- 0.2		TITLE: ASSEMBLY DRG FOR RECESS DESIGNER CASE SIZE 2 GREY			
DRAWN LEWIS LETCHFORD L.L. 15/04/2014				FINISH. LIGHT SPARK		DWG NO. CRDCGG002		A4	
CHKD - - -				MATERIAL. UL 94 - V0 ABS		SCALE. 1:2		SHEET 1 OF 1	
				PROJECTION.					